

# JDS

## Jitter and Delay Simulator

Jitter and Delay Simulator (JDS) is a transparent ethernet bridge that delays incoming packets and induces jitter based on models of free space transmission time and the effects of the TSAT XDR+ waveform. It can be easily integrated with an existing network test lab to assess network and/or application performance given the jitter and delay characteristics of satellite communications systems.

### Features

- Compatible with most COTS routers
- Uses standard 802.3 flow control mechanisms
- Models free space transmission, encoding/decoding, channel interleaving, packet fragmentation, and TDM structure
- User configurable modulation modes and burst rates
- User configurable fix bandwidth assignments
- Integrates with DAMA models to model effects of dynamic bandwidth assignments, therefore, causing dynamic delay and jitter
- Multi-state Markov blockage model
- Clear channel packet loss due to AWGN
- Includes local graphical user interface and remote SNMP management support

### Applications

- Advanced network testing
- COTS application testing
- Voice and video CODEC testing
- Training exercises in an emulated communications environment

Although the JDS was originally built specifically to model the TSAT XDR+ waveform, the underlying models are based on generic bit rate, TDM, and quantization effects. This allows the JDS to be easily modified to model the delay and jitter characteristics of other systems.

Using the JDS in network and application tests provides a better understanding of the performance TSAT will deliver to the warfighter. Its design makes integrating JDS in other test environments simple—adding additional fidelity with minimal additional effort.

Copyright © 2004-2011 LinQuest Corporation. All rights reserved.

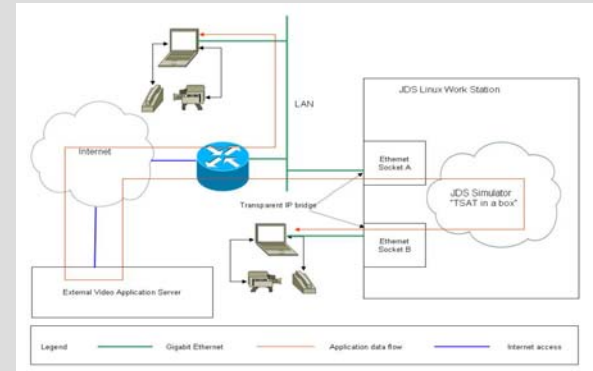

*Sample Emulation Environment*

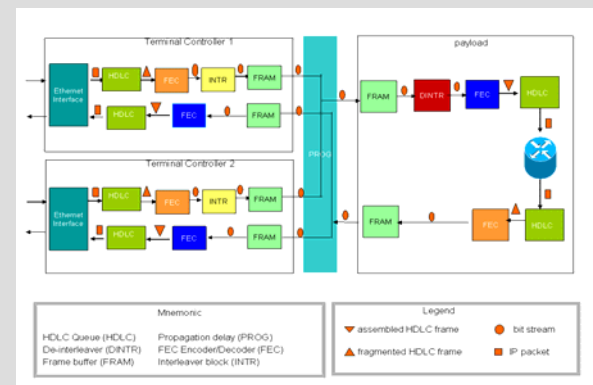

*Internal JDS Components*

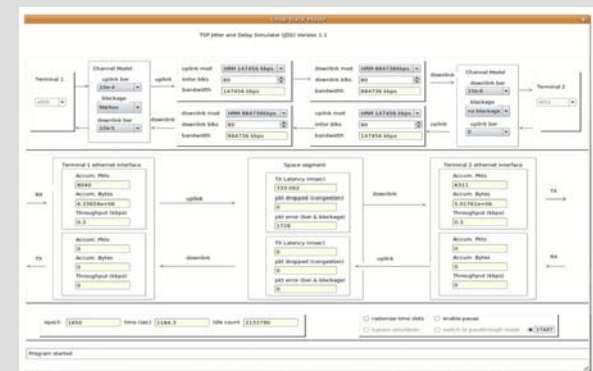

*Configuration and Statistics Display*